

# SUMMIT

# CLARK 3 ANSI

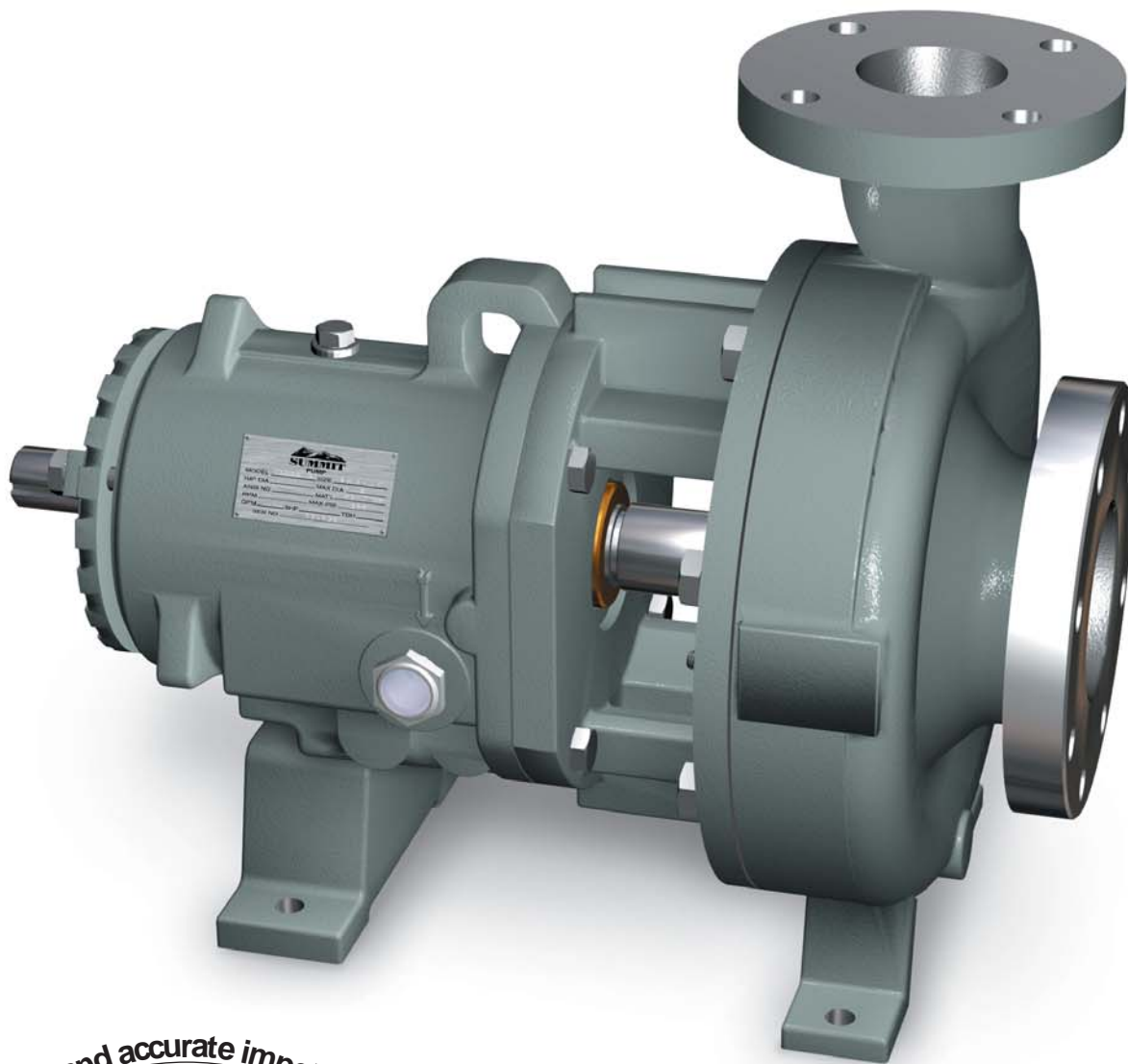

**SUMMIT**™  
**PUMP, Inc**

### Clark 3 Group 1

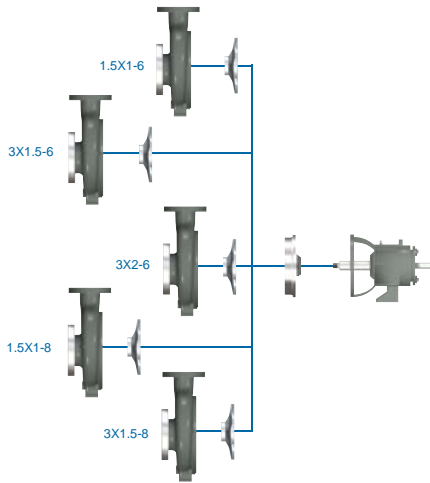

### Clark 3 Group 2

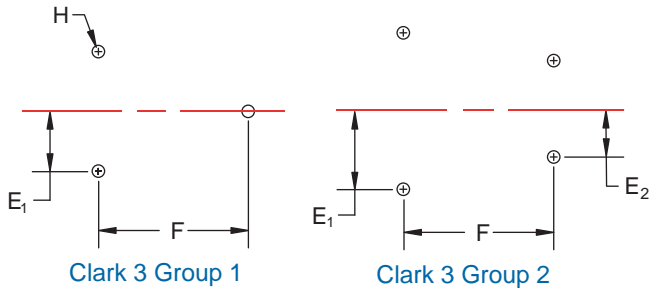
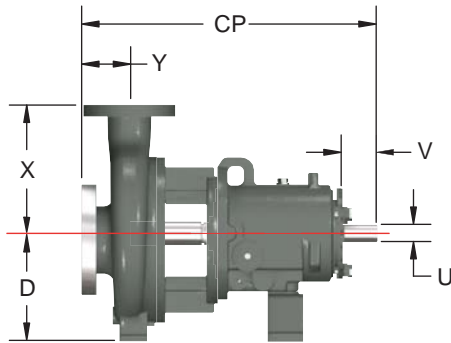
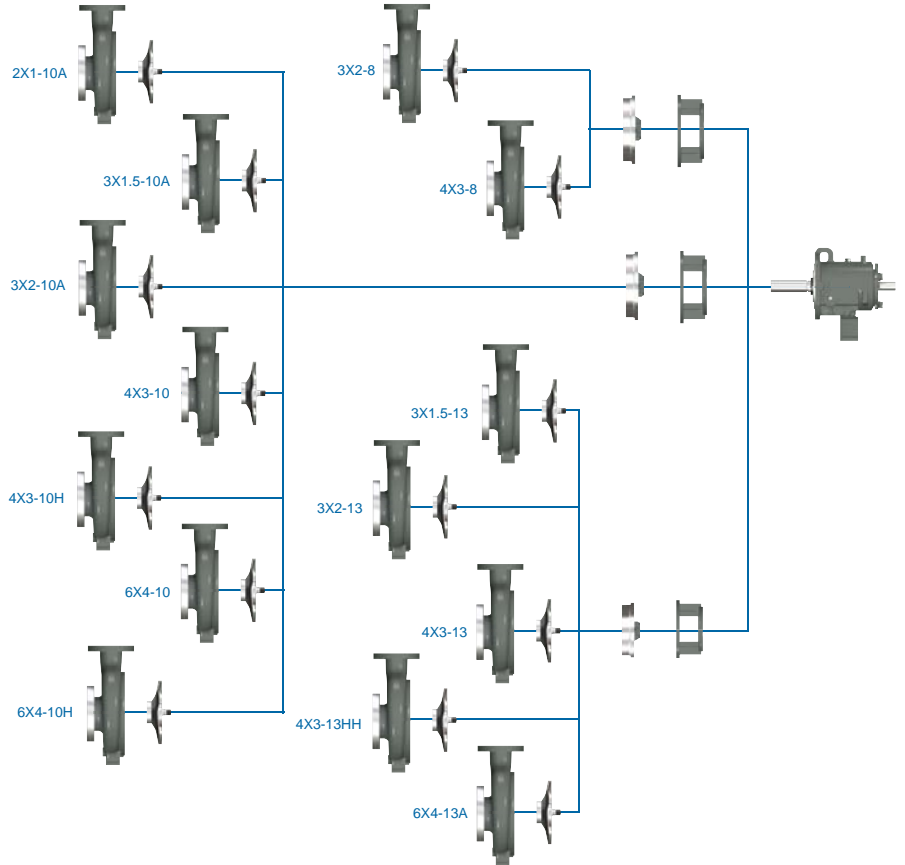

Clark 3 Group 1

Clark 3 Group 2

Pump Group	ANSI Desig.	Size	Pump Dimensions										
			X	D	E <sub>1</sub>	E <sub>2</sub>	CP	F	H	U		V	Y
			in. (mm)	in. (mm)	in. (mm)	in. (mm)	in. (mm)	in. (mm)	in. (mm)	Dia. in. (mm)	Keyway in. (mm)	Min in. (mm)	in. (mm)
Clark3 Group1	AA	1.5 x1-6	6 1/2 (165)	5 1/4 (133)	3 (76)	0	17 1/2 (445)	7 1/4 (184)	5/8 (16)	7/8 (22.3)	3/16x3/32 (4.76x2.38)	2 (51)	4 (102)
	AB	3x1.5-6											
	3x2-6												
	AA	1.5x1-8	7 1/2 (190.5)	7 (177.8)									
Clark3 Group2	A60	3x2-8	9 1/2 (242)	8 1/4 (210)	4 7/8 (124)	3 5/8 (92)	23 1/2 (597)	12 1/2 (318)	5/8 (16)	1 1/8 (28.58)	1/4x1/8 (6.35x3.18)	2 5/8 (67)	4 (102)
	A70	4x3-8	11 (280)										
	A05	2x1-10A	8 1/2 (216)										
	A50	3x1.5-10A	8 1/2 (216)										
	A60	3x2-10A	9 1/2 (242)										
	A70	4x3-10	11 (280)										
	A40	4x3-10H	12 1/2 (318)	10 (254)					1 1/2 (38.1)	3/8x3/16 (9.54x4.76)			
	A80	6x4-10	13 1/2 (343)										
	A80	6x4-10H	13 1/2 (343)										
	A20	3x1.5-13	10 1/2 (266)										
	A30	3x2-13	11 1/2 (292)						1 1/8 (28.58)	1/4x1/8 (6.35x3.18)			
	A40	4x3-13	12 1/2 (318)										
	A40	4x3-13HH	12 1/2 (318)										
	A80	6x4-13A	13 1/2 (343)										